

BOLT TENSIONER MANUAL RETURN - MRT

Bolt coverage from 1" to 3-1/2"
(24 - 100mm) with just 6 tools



MRT MANUAL RETURN BOLT TENSIONER

Our economy range of bolt tensioners offer low-cost tensioning solutions.

Incorporating our unique quick-release bridge adaptation, a range of adapter kits provide maximum flexibility.

- Piston stroke limit indication
- Piston/cylinder misalignment compensation
- Bolt coverage from 1" to 3-1/2" with just 6 tools
- Designed to fit BS1560/ANSI B16.5/API flanges
- Unique quick-release bridge adaption
- Application specific tooling available. Contact factory for details.

Note: Certain tensioners may require minimum order quantity - consult factory for details.

Specifications and Dimensional Data

(Tool Reference)	Stud Diameter				Tool Load		Hydraulic Area		Approx. Wt.		Minimum Bolt Protrusion Above Nut				
	Load Cell Order No.	Imperial	Adaptor Kit Order No.	Metric	Adaptor Kit Order No.	Lbf	kN	in ²	mm ²	lb	kg	Imp bolts		met bolts	
												in	mm	in	mm
(MRT1) MRTAS010001	1"	MRTAS010002	M24	MRTAS010004	62,900	280	2.894	1,867	6.6	3	0.98	25	0.94	24	
	-	-	M27	MRTAS010005							-	-	1.06	27	
	1-1/8"	MRTAS010003	-	-							1.14	29	-	-	
(MRT2) MRTAS020001	1"	MRTAS020002	M24	MRTAS020006	101,100	450	4.652	3,001	9.9	4.5	0.98	25	0.94	24	
	-	-	M27	MRTAS020007							-	-	1.06	27	
	1-1/8"	MRTAS020003	M30	MRTAS020008							1.14	29	1.18	30	
	1-1/4"	MRTAS020004	M33	MRTAS020009							1.26	32	1.30	33	
	1-3/8"	MRTAS020005	M36	MRTAS020010							1.38	35	1.42	36	
(MRT3) MRTAS030001	1-1/4"	MRTAS030002	M33	MRTAS030006	148,300	660	6.822	4,401	12.98	5.9	1.26	32	1.30	33	
	1-3/8"	MRTAS030003	M36	MRTAS030007							1.38	35	1.42	36	
	1-1/2"	MRTAS030004	M39	MRTAS030008							1.50	38	1.54	39	
	1-5/8"	MRTAS030005	M42	MRTAS030009							1.61	41	1.65	42	
	1-1/4"	MRTAS040003	M39	MRTAS040008							1.26	32	1.54	39	
(MRT4) MRTAS040001	1-5/8"	MRTAS040004	M42	MRTAS040009	224,700	1,000	10.335	6,668	18.7	8.5	1.61	41	1.65	42	
	1-3/4"	MRTAS040005	M45	MRTAS040010							1.73	44	1.77	45	
	1-7/8"	MRTAS040006	M48	MRTAS040011							1.89	48	1.89	48	
	2"	MRTAS040007	-	-							2.01	51	-	-	
	2"	MRTAS050003	M52	MRTAS050007							2.01	51	2.05	52	
(MRT5) MRTAS050001	2-1/4"	MRTAS050004	M56	MRTAS050008	337,200	1,500	15.505	10,003	30.8	14	2.24	57	2.20	56	
	-	-	M60	MRTAS050009							-	-	2.36	60	
	2-1/2"	MRTAS050005	M64	MRTAS050010							2.52	64	2.52	64	
	-	-	M68	MRTAS050011							-	-	2.68	68	
	-	-	M70	MRTAS050012							-	-	2.76	70	
	2-3/4"	MRTAS050006	-	-							2.76	70	-	-	
	2-3/4"	MRTAS060003	M72	MRTAS060007							2.01	51	2.83	72	
(MRT6) MRTAS060001	3"	MRTAS060004	M76	MRTAS060008	562,000	2,500	25.84	16,671	50.6	23	2.99	76	2.99	76	
	-	-	M80	MRTAS060009							-	-	3.15	80	
	3-1/4"	MRTAS060005	M85	MRTAS060010							3.27	83	3.35	85	
	3-1/2"	MRTAS060006	M90	MRTAS060011							3.50	89	3.54	90	
	3-1/2"	MRTAS070003	M90	MRTAS070006							3.50	89	3.54	90	
(MRT7) MRTAS070001	-	-	M95	MRTAS070007	719,300	3,200	33	21,339	70.4	32	-	-	3.74	95	
	3-3/4"	MRTAS070004	M100	MRTAS070008							3.74	95	3.94	100	
	4"	MRTAS070005	-	-							4.02	102	-	-	
	-	-	-	-							-	-	-	-	

To convert to long tons, divide lbf by 2240. To convert to short tons, divide lbf by 2000.

Specifications and Dimensional Data

Piston stroke: 15mm (excluding MRT1 - 10mm)

Max tool pressure: 1,500 bar (21,750 psi)

Bolt protrusion above nut: 1 x bolt diameter

'D' includes an allowance for tool removal after bolt tightening with 15mm tool stroke

Weight excludes puller sleeve

To make a complete MRT Tensioner, choose an Adapter Kit and a Load Cell.

Semi-compatible with SRT tensioners. Only compatible with SRT Bridges; NOT puller sleeves. SRT Puller Sleeves cannot be used with MRT Load Cell.

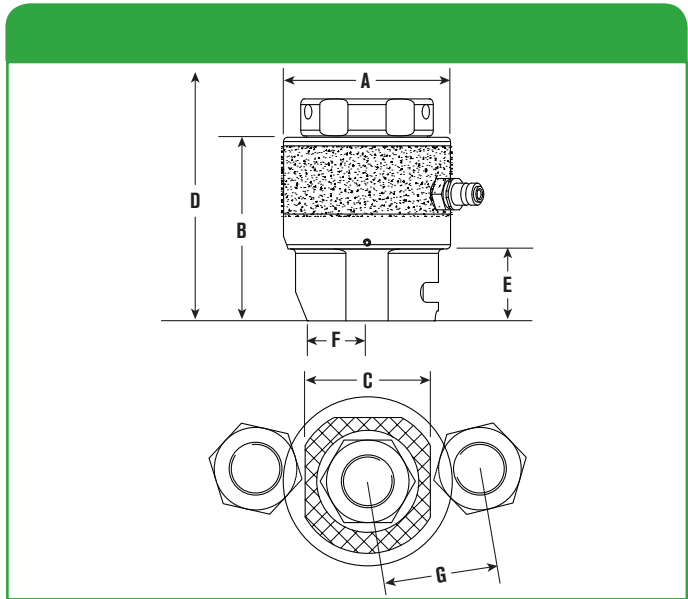

	A		B		C		D				E		F		G				Stud Diameter		(Tool Reference) Load Cell Order No.
	in	mm	in	mm	in	mm	Imp bolts		met bolts		in	mm	in	mm	Imp bolts		met bolts		Imperial	Metric	
3.35	85	3.8	97	2.7	68	6.6	166.8	6.1	155.4	1.5	38	1.1	28	2.3	59	2.2	56	1"	M24	(MRT1) MRTAS010001	
		3.8	97	2.7	68	-	-	6.2	158.4	1.5	38	1.1	28	-	-	2.3	59	-	M27		
		3.9	100	3	76	6.8	173.2	-	-	1.6	41	1.2	31	2.6	66	-	44	1-1/8"	-		
4.25	108	4	102.5	3	75	7.2	181.8	7.1	180.4	1.5	38	1.2	30	2.7	68	2.6	67	1"	M24	(MRT2) MRTAS020001	
		4	102.5	3	75	-	-	7.2	183.4	1.5	38	1.2	30	-	-	2.7	69	-	M27		
		4.2	105.5	3.1	80	7.4	188.2	7.5	189.6	1.6	41	1.2	30	2.7	69	2.8	70	1-1/8"	M30		
		4.3	108.5	3.3	84	7.7	194.5	7.7	195.8	1.7	44	1.4	35	2.8	72	2.8	72	1-1/4"	M33		
4.9	147.5	4.4	111.5	3.5	89	7.9	200.9	7.9	201.9	1.9	47	1.5	38	3.1	78	3	77	1-3/8"	M36	(MRT3) MRTAS030001	
		4.3	108.5	3.5	88	7.7	196.5	7.8	197.8	1.7	44	1.4	35	3.1	79	3.1	80	1-1/4"	M33		
		4.4	111.5	3.8	96	8	203	8	204	1.9	47	1.5	38	3.2	81	3.2	81	1-3/8"	M36		
		4.5	115	3.8	96	8.2	209.2	8.3	210.1	2	50.5	1.7	42	3.3	84	3.3	84	1-1/2"	M39		
5.8	147.5	4.6	118	4.1	105	8.5	215.6	8.5	216.3	2.1	53.5	1.6	41	3.6	91	3.6	91	1-5/8"	M42	(MRT4) MRTAS040001	
		4.6	116	4.4	112	8.5	215.2	8.5	216.1	2	50.5	1.7	42	3.7	94	3.7	94	1-1/4"	M39		
		4.7	119	4.5	114	8.7	222	8.7	222	2.1	53.5	1.8	45	3.8	96	3.8	96	1-5/8"	M42		
		4.8	122.5	4.6	118	9	227.9	9	228.5	2.2	57	2	52	3.9	100	3.9	100	1-3/4"	M45		
		4.9	125.5	4.5	114	9.2	234.3	9.2	234.6	2.4	60	2	51	4	101	4	101	1-7/8"	M48		
7.1	180.5	5.1	128.5	4.7	120	9.5	241	-	-	2.5	63	2	52	4.2	107	-	-	2"	-	(MRT5) MRTAS050001	
		5.2	132	4.7	120	9.9	250.6	9.9	251.8	2.5	63	2	52	4.6	117	4.6	117	2"	M52		
		5.5	138.5	5.4	138	10.4	263.3	10.3	262.2	2.7	69.5	2.3	58	4.8	121	4.7	119	2-1/4"	M56		
		5.5	138.5	5.4	138	-	-	10.5	266	2.7	69.5	2.3	58	-	-	4.8	122	-	M60		
		5.7	145	6	153	10.9	276	10.9	276.5	3	76	2.5	63	5.3	134	5.2	132	2-1/2"	M64		
		5.7	145	6	153	-	-	11	280.5	3	76	2.5	63	-	-	5.3	135	-	M68		
		5.7	145	6	153	-	-	11.1	282.5	3	76	2.5	63	-	-	5.3	135	-	M70		
8.9	227	5.9	150	6.1	156	11.4	289	-	-	3.2	81	2.8	70	5.6	141	-	-	2-3/4"	-	(MRT6) MRTAS060001	
		5.9	151	6.2	157	11.8	298.7	11.8	300.9	3.2	82	2.8	72	5.9	149	5.9	151	2-3/4"	M72		
		6.2	158	7.2	182	12.3	311.4	12.3	311.2	3.5	89	3.1	80	6.3	160	6.1	156	3"	M76		
		6.2	158	7.2	182	-	-	12.4	315.2	3.5	89	3.1	80	-	-	6.2	158	-	M80		
		6.5	164	7.5	190	12.8	324.1	12.9	326.6	3.7	95	3.3	84	6.7	169	6.5	165	3-1/4"	M85		
10	252	6.7	170	8.1	205	13.3	336.8	13.3	337.9	4	101	3.5	88	7.2	182	7	179	3-1/2"	M90	(MRT7) MRTAS070001	
		6.8	173	7.9	200	13.6	346	13.7	347	4	101	3.5	88	7.1	180	6.9	176	3-1/2"	M90		
		0	6.8	173	7.9	200	-	-	13.9	351.9	101	3.5	88	-	-	7	179	-	M95		
		0	7	179	7.9	200	14.1	358.5	14.3	363.3	107	3.7	94	7.3	185	7.3	185	3-3/4"	M100		
		0	7.3	186	8.3	210	14.6	371.2	-	-	114	4.5	114	7.5	190	-	-	4"	-		

For smaller or larger sizes, see SRT product pages.

Toggle Bar	10mm x 200mm	SRT/MRT (up to 1-7/8" - M48)	INTTB000010
	14mm x 200mm	SRT/MRT (2" - M52 and above)	INTTB000014