

ARCONIC
Innovation, engineered.

Instruction Manual

940

Powerig® Hydraulic Power Source



Serial Number Notice
2

Safety Instructions
3

Description
4

Principle of Operation
4

Preparation for Use
4

Specifications
5

Checking and Adjusting Pressures
5

Operation
5

Maintenance
6

Components Drawings
7-10

Options and Accessories
11

Troubleshooting
11



August 10, 2017
HK496

Makers of Huck®, Marson®, Recoil®
Brand Fasteners, Tools & Accessories



NOTICE





This manual applies to 940
serial number 3927 and above.

For any other serial numbers, please contact a Huck customer service representa-
tive.



Safety Instructions

GLOSSARY OF TERMS AND SYMBOLS:

-  - Product complies with requirements set forth by the relevant European directives.
-  - Read manual prior to using this equipment.
-  - Eye protection is required while using this equipment.
-  - Hearing protection is required while using this equipment.

Notes: are reminders of required procedures.

Bold, Italic type, and underline: emphasize a specific instruction.

 **WARNINGS: Must be understood to avoid severe personal injury.**

 **CAUTIONS: Show conditions that will damage equipment or structure.**

1. A half hour long hands-on training session with qualified personnel is recommended before using Huck equipment.
2. Huck equipment must be maintained in a safe working condition at all times. Tools and hoses should be inspected at the beginning of each shift/day for damage or wear. Any repair should be done by a qualified repairman trained on Huck procedures.
3. Repairman and Operator must read manual prior to using equipment. Warning and Caution stickers/labels supplied with equipment must be understood before connecting equipment to any primary power supply. As applicable, each of the sections in this manual have specific safety and other information.
4. Read MSDS Specifications before servicing the tool. MSDS Specifications are available from the product manufacturer or your Huck representative.
5. When repairing or operating Huck installation equipment, always wear approved eye protection. Where applicable, refer to ANSI Z87.1 - 2003
6. Only genuine Huck parts shall be used for replacements or spares. Use of any other parts can result in tooling damage or personal injury.
7. If a part affixed with warning labels is replaced, or labels are missing or damaged, the end user is responsible for replacement. Refer to assembly drawing and parts list for replacement part number and proper placement.
8. Disconnect primary power source before performing maintenance on Huck equipment or changing Nose Assembly.
9. Tools and hoses should be inspected for leaks at the beginning of each shift/day. If any equipment shows signs of damage, wear, or leakage, do not connect it to the primary power supply.
10. Mounting hardware should be checked at the beginning of each shift/day.
11. Make sure proper power source is used at all times.
12. Release tool trigger if power supply is interrupted.
13. Tools are not to be used in an explosive environment unless specifically designed to do so.
14. Never remove any safety guards or pintail deflectors.
15. Where applicable, ensure deflector or pintail collector is installed and operating prior to use.
16. Never install a fastener in free air. Personal injury from fastener ejecting may occur.
17. Where applicable, always clear spent pintail out of nose assembly before installing the next fastener.
18. There is possibility of forcible ejection of pintails or spent mandrels from front of tool.
19. Check clearance between trigger and work piece to ensure there is no pinch point when tool is activated. Remote triggers are available for hydraulic tooling if pinch point is unavoidable.
20. Unsuitable postures may not allow counteracting of normal expected movement of tool.
21. Do not abuse tool by dropping or using it as a hammer. Never use hydraulic or air lines as a handle or to bend or pry the tool. Reasonable care of installation tools by operators is an important factor in maintaining tool efficiency, eliminating downtime, and in preventing an accident which may cause severe personal injury.
22. Never place hands between nose assembly and work piece. Keep hands clear from front of tool.
23. There is a risk of crushing if tool is cycled without Nose Assembly installed.
24. Tools with ejector rods should never be cycled with out nose assembly installed.
25. When two piece lock bolts are being used always make sure the collar orientation is correct. See fastener data sheet for correct positioning.
26. Tool is only to be used as stated in this manual. Any other use is prohibited.
27. There is a risk of whipping compressed air hose if tool is pneudraulic or pneumatic.
28. Release the trigger in case of failure of air supply or hydraulic supply.
29. Use only fluids or lubricants recommended.
30. Disposal instruction: Disassemble and recycle steel, aluminum and plastic parts, and drain and dispose of hydraulic fluid in accordance with local lawful and safe practices.
31. If tool is fixed to a suspension device, ensure that the device is secure prior to operating the tool.

Where the following trade names are used in this manual, please note:

DEXRON is a registered trademark of General Motors Corporation.
Loctite is a registered trademark of Henkel Corporation, U.S.A.
LUBRIPLATE is a registered trademark of Fiske Brothers Refining Co.
MERCON is a registered trademark of Ford Motor Corp.
Never-Seez is a registered trademark of Bostik, Inc.
Quintolubric is a registered trademark of Quaker Chemical Corp.
Slic-tite is a registered trademark of LA-CO Industries, Inc.
Spürolox is a registered trademark of Smalley Steel Ring Company
Teflon is a registered trademark of E. I. du Pont de Nemours and Company.
Threadmate is a registered trademark of Parker Intangibles LLC.
TRUARC is a trademark of TRUARC Co. LLC.
Vibra-Tite is a registered trademark of ND Industries, Inc. USA.



Description

Figures 1 & 5

Model 940 Powerig® Hydraulic Power Source is a portable, electrically-operated power source designed to operate all Huck hydraulic installation equipment, excluding Huck-Spin® tools. It operates on 115 volt AC, 50-60 Hz, one-phase electrical power. The power cord is a 10/3 SJTO cord with a NEMA L5-30 plug. The motor is rated at 115V, 50/60Hertz, 25A. An electrical enclosure contains a motor contact, transformer, relay and circuit breaker. Hydraulic pressure occurs by a two-stage, gear-piston pump driven by a 1 1/8 horsepower universal electric motor. Pressurized fluid is directed by a four-way directional valve to either the PULL or RETURN port of the installation equipment. The four-way directional valve is operated by a 24 volt AC control circuit. The high pressure relief valve controls PULL pressure (maximum pressure of the unit) and is adjustable by the operator. An internal relief valve is preset at the factory to protect the Operator and equipment. The internal relief is not adjustable by the operator. A pressure switch controls RETURN pressure and turns off the Powerig at the end of an installation cycle. Pressures are adjustable to match Huck equipment being used. See applicable tool instruction manual for pressure settings for other Huck installation equipment. Hydraulic fluid is stored in the reservoir which also serves as the base. Remove the filler cap/dipstick to check fluid level and to add fluid. Hydraulic quick disconnect couplers are furnished for connecting hoses from installation equipment.

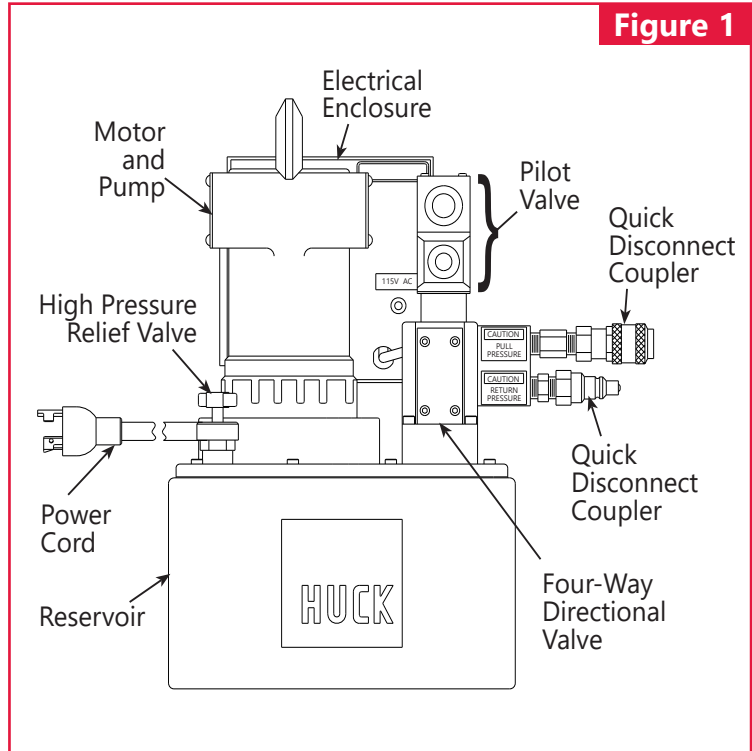

Figure 1

Principle of Operation

FIGURE 2

Pressure switch (PS) contacts are normally closed. Increasing pressure opens contacts. When the tool trigger switch is depressed, 24 volts AC is applied between relay terminals CR13 and CR14 activating the relay coil and closing two sets of contacts, CR9-CR5 and CR12-CR8. Closing contacts CR9-CR5 starts the motor. Closing contacts CR12-CR8 activates the solenoid coil of the pilot valve. The pilot valve shifts the directional valve spools.

Pressurized fluid is directed to the PULL pressure port of the installation equipment. When the tool trigger switch is released, the relay contacts open. The solenoid coil is deactivated and the spring return of the pilot valve shifts the directional valve spools. Pressurized fluid is directed to the RETURN pressure port of the installation equipment.

The motor contact is held closed until the preset RETURN pressure is reached and pressure switch (PS) contacts open. The motor turns off, the pressure drops, and pressure switch returns to the closed (normal) position.

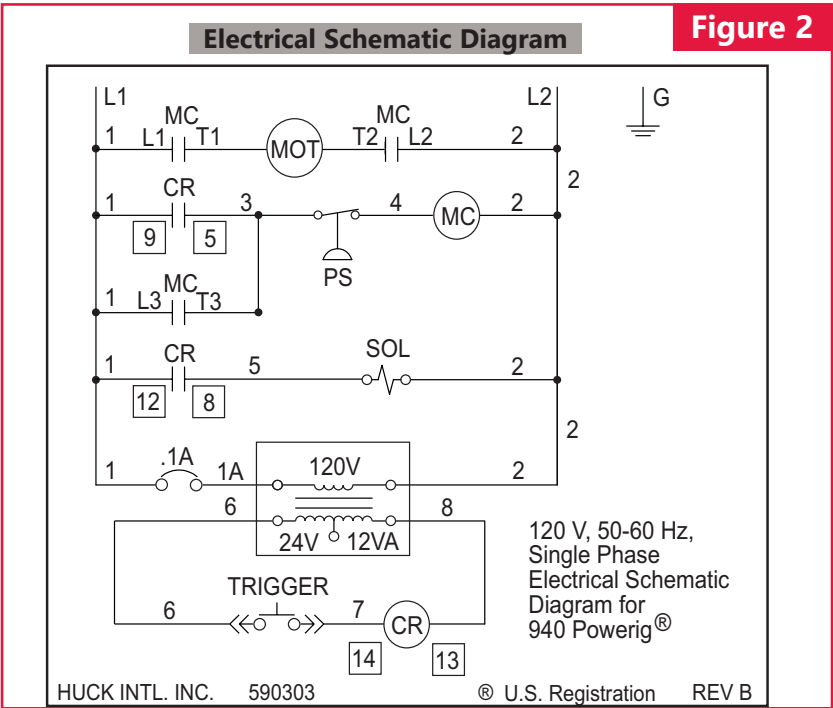

Figure 2

Preparation for Use

SERVICE

Introduction of foreign material into Hydraulic Unit will result in poor performance and down time for repair. To avoid this: Clean the area around the filler cap before adding hydraulic fluid, always use a clean funnel with a filter, keep quick-disconnect couplers clean by keeping them off the floor, and wipe off quick-disconnect couplers before connecting them.

BEFORE USE

Fill the reservoir with hydraulic fluid, approximately 2.6 gallons (9.8 liters), until the fluid level is between the grooves of the dipstick.

The 940 Powerig is shipped without hydraulic fluid.



Specifications

CSA-US CERTIFIED

940 Powerigs are intended for use in indoor factory environments, and if used outdoors they must be protected from the elements.

WIDTH: 16.1 inches (40.9 cm)

LENGTH: 13.9 inches (35.4 cm)

HEIGHT: 18.5 inches (47 cm)

WEIGHT: 66 pounds (30 kg) (with empty reservoir)

ELECTRICAL SYSTEM: 115VAC (25A), 50/60hz, single phase

CONTROL SYSTEM: Solenoid operated directional valve, 24V

MOTOR: 12000 RPM, 1-1/8 HP, 25 amps. nominal

PUMP: 2-stage, gear-piston type, 70 in³/min @5,000 psi out pressure (Output pressure adjustable to 10,000 psi)

RESERVOIR CAPACITY: 2.6 gallons (9.8 liters)

PRESSURE SETTING AS SHIPPED:

RETURN: 2,200-2,400 psi (15,200-16,500 kPa)

PULL: 5,400 - 5,700psi (37,200 - 39,300 kPa)

Minimum Operating Temperature (ambient): 0° (18°C)

Maximum Hydraulic Fluid Temperature: 150°F (65°C)

HYDRAULIC FLUID: Hydraulic fluid shall meet DEXRON® III, DEXRON VI, MERCON, Allison C-4 or equivalent ATF specifications.

Fire resistant fluid may be used if it is an ester based fluid such as Quintolubric HFD or equivalent. Water based fluid shall NOT be used as serious damage to equipment will occur.

Checking and Adjusting Pressures



WARNINGS:

Maximum PULL pressure is 8400 psi. Refer to specific tool instruction manual for PULL and RETURN pressures. Severe personal injury may occur if excessive pressures cause violent failure of equipment. Higher than normal pressures will also cause premature wear of equipment.

If recommended maximum pressure is exceeded, violent failure of fastening system may occur. This may cause severe personal injury.

CHECKING PRESSURES

WARNINGS above must be understood. Check PULL and RETURN pressures before use, before troubleshooting, and after overhauling. See pressures given in the specific tool instruction manual. For checking pressures, use T-124833CE Pressure Gauge and its instruction manual.

ADJUSTING PRESSURES

NOTE: Using gauge T-124833CE, set pressures according to the specific installation equipment manual.

ADJUSTING PULL PRESSURE

NOTE: PULL pressure is the maximum Powerig® pressure. Do not exceed the pressure rating of the installation equipment. See the installation equipment manual for pressure rating.

1. Loosen the jam nut of the high pressure relief valve.
2. Turn the adjusting screw clockwise to increase PULL pressure OR counterclockwise to decrease PULL pressure.
3. Tighten the jam nut after PULL pressure has been adjusted.
4. Check PULL pressure. Follow instructions in the appropriate section of this manual.

ADJUSTING RETURN PRESSURE

1. Loosen the jam nut on pressure switch.
2. Turn the adjusting screw clockwise to increase RETURN pressure OR counterclockwise to decrease RETURN pressure.
3. Tighten the jam nut on pressure switch after return pressure has been adjusted.
4. Check RETURN pressure. Follow instructions in the appropriate section of this manual.

Operation

Before each use:

1. Check the fluid level in the reservoir and add hydraulic fluid as required.
2. Inspect hoses for damage and wear. If hoses show wear that has removed more than the surface texture, they must be replaced.
3. Check the entire system and repair any leaks.
4. Check electrical cord and extension for abrasion and replace as required.

Be sure that the hose from PULL PRESSURE on the control panel runs to the port stamped with a letter 'P' on the tool, and the hose from RETURN PRESSURE on the control panel runs to the port stamped with letter 'R' on the tool.

Plug the control cable from the tool into the two-prong socket on the POWERIG Hydraulic Unit control panel. Depress the tool trigger switch and let the POWERIG Hydraulic Unit operate for a few minutes to circulate fluid and remove air from the system.

Attach a nose assembly to the installation equipment. Fasteners may now be installed. Follow instructions in the tool manual.

Operating Tools:

Plug the power cord into a grounded wall outlet.

Check pressures and adjust as necessary. See the appropriate sections in this manual. **WARNINGS must be understood before checking pressures.** Connect hydraulic hoses from a HUCK hydraulic tool to the Powerig.



Maintenance

PREVENTIVE MAINTENANCE

An effective preventive maintenance program includes scheduled inspections to detect and correct minor troubles. Perform the following steps monthly during normal use:

- Ensure secure fit of hydraulic and electrical fittings.
- Inspect hoses for signs of damage. Replace hoses if abrasion is deeper than the surface texture.
- Rotate hoses end-for-end to equalize wear and fatigue.
- Inspect during operation to detect any abnormal heating, vibration or leakage.
- Inspect hydraulic fluid. If contamination (particles, water, sludge, etc.) is detected, clean reservoir and replace fluid.
- Clean exterior surfaces.
- Check supply voltage. Do not operate the Powerig® Hydraulic Unit if the line voltage is more than 5 percent above or below 115 Volts.
- Check motor brushes. See figure below.

SPARE PARTS

The quantity of spare parts that should be kept on hand varies with the application and number of the Powerig Hydraulic Units in service. Parts that should be available to the service technician are: Pump-to-Motor Coupling, Relay, Transformer, Pilot Valve, and Motor Brushes. See **Options and Accessories** section of this manual for part numbers.

DIRECTIONAL VALVE OVERHAUL

If overhaul of the directional valve is necessary, a valve repair kit that has the spools, cartridges & poppets is 129437, is available for purchase, and should be kept on hand. To rebuild valve, follow instructions included with kit.

PUMP OVERHAUL

If pump requires overhaul return it, or the complete unit, to the nearest repair facility shown on the inside back cover.

REPLACING PUMP-TO-MOTOR COUPLING

Pump-to-motor coupling can be replaced by removing four socket cap screws holding the motor housing to the cover plate and lifting the motor to one side. Lift out the original coupling with needle-nose pliers. Drop in the new coupling, align the slots and reassemble motor to cover plate.

INTERNAL ADJUSTMENT OF PRESSURE SWITCH

1. Remove the top cover of the switch.
2. Loosen two screws located in bottom of switch housing.
3. Place a 0.20-inch-thick shim between the spring retainer and the platen.
4. Loosen the set screw on the spring retainer until it contacts shim.
5. Lock the spring retainer in place with the set screw.
6. Slide the switch mounting bracket toward the switch button until it contacts the platen surface.
7. Secure with two screws located in the middle of the bottom cover.
8. Connect a volt/ohm meter to the electrical cord.
9. Tighten the switch adjustment screw against the switch mounting bracket until the switch button contacts the platen and actuates. The volt/ohm meter will react when the button actuates. A click can be heard.
10. Continue tightening the switch adjustment screw 1/8 of a turn after the switch button actuates.
11. Replace the top cover of the switch.

SERVICE PERIOD	ACTION	BEFORE EACH USE	EVERY 50 HOURS	EVERY 100 HOURS	EVERY 200 HOURS
Hydraulic Hose Fittings	Check-Clean	•			
Electrical Connections	Check	•			
Hydraulic Fluid Level, Fill Cap Tight	Check	•			
Verify Pull & Return Pressure, Tighten Adjustment Screw Jam Nuts	Check		•		
Tighten Cover Plate Screws	Check		•		
Tighten Screws on Engine	Check		•		
Change Hydraulic Fluid, Clean Tank	Change				• (Notes 1 and 2)
Check Motor Brushes	Check			•	
Directional Valve Seals, Poppets & Seats	Check				• (Note 3)
External Relief Valve Stem	Check				• (Note 4)

Notes:

1. Service more frequently when used in dusty areas.
2. Hydraulic fluid: use 32AW (0°F - 70°F ambient), 46AW (30°F - 120°F ambient), or ATF (30°F - 90°F ambient).
3. If poppets show wear, use Huck Directional Valve Kit to replace poppets, seats & seals.
4. If valve stem shows wear, replace with Huck Valve Stem.

CHECKING MOTOR BRUSHES

Checking motor brushes frequently helps to prevent premature failure of the armature. To check the brushes:

1. Remove the metal brush cover plates.
2. Unscrew the plastic brush holder caps. **Note: Springs on the brushes will push on the caps. Hold the caps as they are loosened.**
3. Remove brush assemblies.
4. Clean copper commutators on the armature with a pencil eraser.
5. Clean out spaces between connections with a plastic tool. If commutator is damaged or worn, replace armature with Armature/Field Kit, which is included in the Motor Service Kit. See **Options and Accessories** section of this manual for part numbers.
6. Measure the length of the carbon brush, and replace both brushes if either one is 1/4 inch or less in length.
7. Install brush assemblies, brush holder cups, and metal brush cover plates.

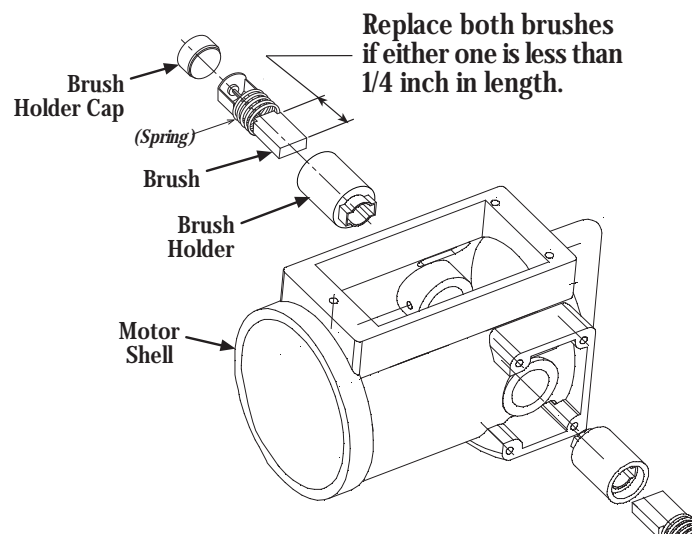



111345 Pump, Motor, Valve Assembly

Figure 4

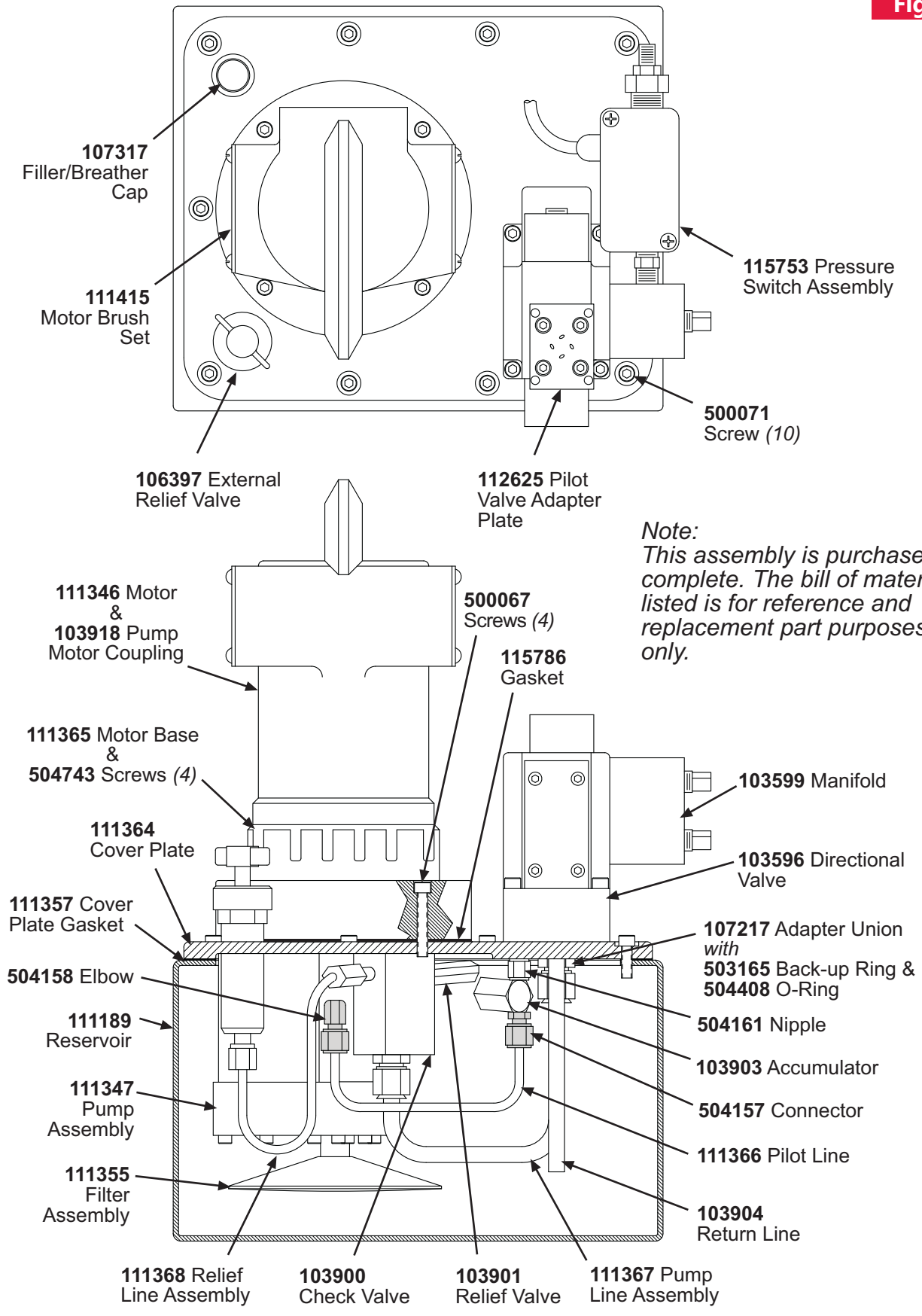

Note:
 This assembly is purchased complete. The bill of material listed is for reference and replacement part purposes only.



Electrical Schematic and Wiring Diagram

Figure 6

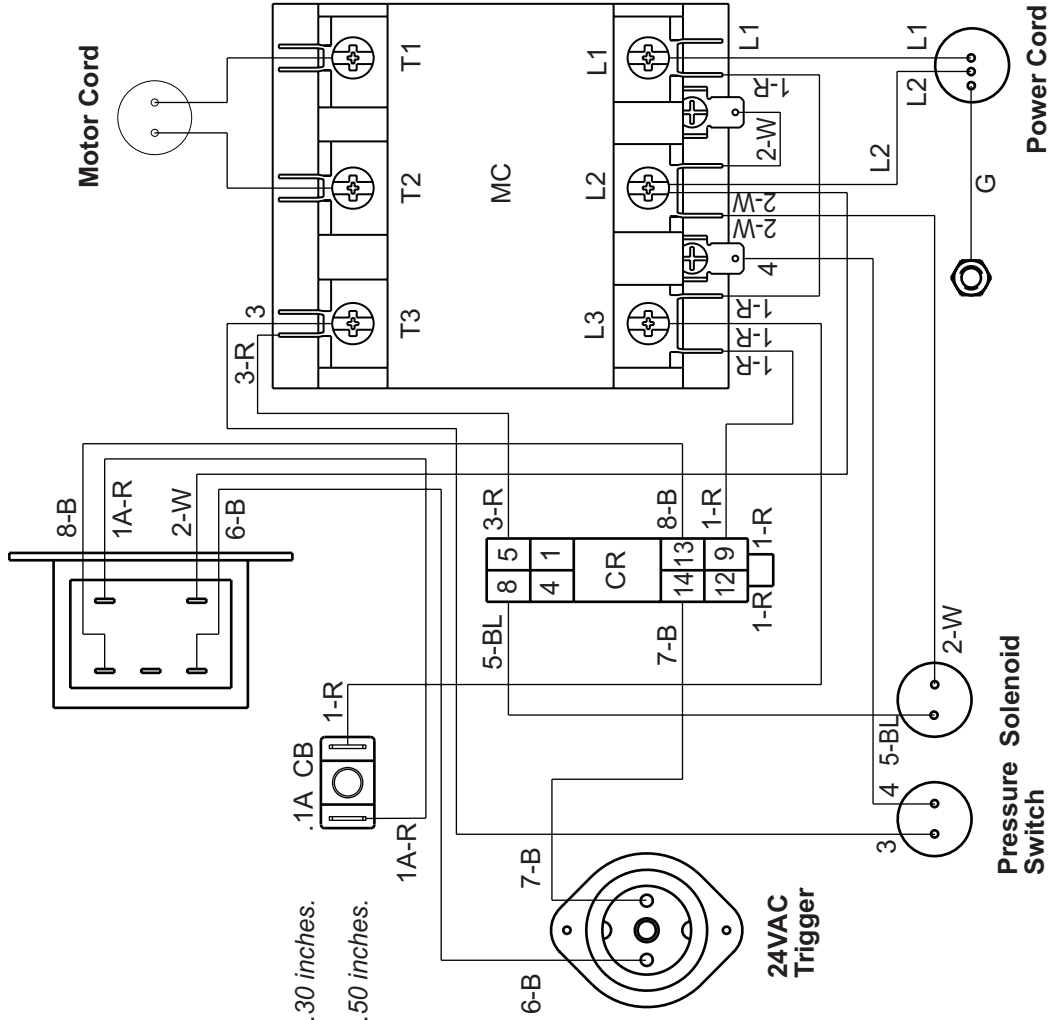

Notes:

1. Wire Label Code: XX - XX
 R = Red
 W = White
 B = Blue
 BL = Black
 Indicates alphanumeric label to appear at both ends of the conductor.
2. Connections made to 506365 Socket Relay, strip end of wire 0.30 inches.
3. Connections made to 110685 Female Base, strip end of wire 0.50 inches.
4. Wire color code for Power Cord:
 L1 = Light Blue or Black
 L2 = Brown or White
 G = Green/Yellow or Green
5. Wire color code for Pressure Switch:
 3 = Light Blue or Black
 4 = Brown or White

TERMINAL	WIRE NUMBER LOCATION
505704	Power Cord L1 & L2 & G
505705	Pressure Switch 4
505744	Pressure Switch 3 & Motor Wires

Wire No.	Color	From	To
1A	red	transformer lower right	circuit breaker
1	red	CR12	CR9
1	red	circuit breaker	MCL3
1	red	MCL1	MCL3
1	red	MCL3	CR9
2	white	MCL2	transformer lower left
2	white	MC terminal	MCL2
3	red	MCT3	CR5
6	blue	transformer upper left	trigger
7	blue	trigger	CR14
8	blue	transformer upper right	CR13



111346 Motor

Figure 7

NOTES:

1. Press bearings into armature, and install as a unit into the motor shell. Apply Loctite® 277 Threadlocker, or equivalent, between outer race and bore. Place motor in an upright position while Loctite cures.
2. Brush Holders must be installed with slot and dimple facing the open end of the Motor Shell. Apply Loctite® 680™ Retaining Compound, or equivalent, between Brush Holder and bore.
3. Insert Flag Terminals into adjacent Brush Holders.
4. Line leads must be routed through the rectangular opening in the Motor Shell.

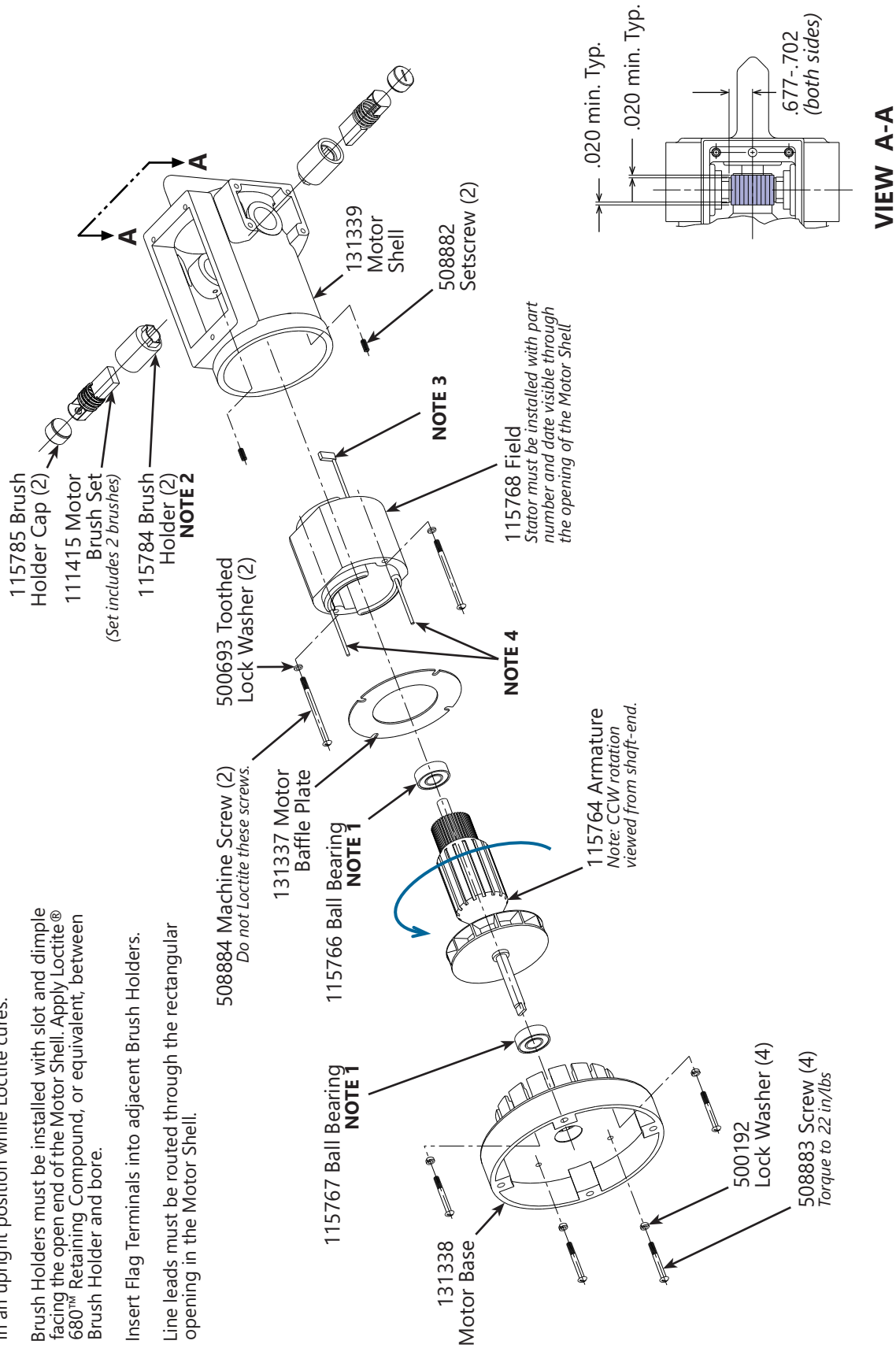

111346_revE



Options & Accessories

OPTIONS

940T-1 (Special Version of 940)

The 940T-1 is part of Huck's revised aftermarket Truck Kits, which contain different pressure installation tools. This hydraulic unit will be shipped from the factory with output pressures set as follows:
PULL: 5700-5800 psi RETURN: 4400-4600 psi

ACCESSORIES:

Auxiliary Switch and Control Cord 113056

An auxiliary switch is available for use when checking and adjusting pressures and when troubleshooting.

Gauge T-124833CE

A "T" gauge is available for use when checking and adjusting pressures, and troubleshooting.

Hose and Control Cord Kits of various lengths
Please contact your HUCK representative.

Directional Valve Kit 129437

Includes seals necessary to service Directional Valve 103596.

Rig Transport Dolly 129703

Heavy duty steel dolly for easy movement of powerig throughout the work area.

Motor 111346

Motor and Pump Assembly 111345

Motor Service Kit 115770

includes:

Motor Brushes Set	111415
115V Armature	115764
Upper Bearing	115766
Lower Bearing	115767
115V Motor Field	115768
Brush Holder	115784
Brush Holder Cap	115785
Gasket	115786

Troubleshooting

Always check the simplest possible cause of malfunction first. For example, blown fuse, tripped circuit breaker, defective switch or control cord. Eliminate each possible cause until the defective circuit or part is located. Where possible, substitute known good parts for suspected bad parts. A qualified electrician should check out the electrical system. Use this section as an aid in locating trouble and correcting it.

- Motor fails when tool switch is depressed:
 - Loose or defective control cord or connectors.
 - Power source not properly fused.
 - Defective tool switch.
 - Loose wire(s).
 - Defective relay.
 - Incorrect power source.
 - Defective motor contactor.
 - Defective transformer
- Motor runs, but tool will not reciprocate:
 - Hoses not coupled properly.
 - Hydraulic fluid viscosity not proper or level is low.
 - Defective pilot valve solenoid or coil.
 - Unloading valve missing in tool.
 - Bind in tool or nose assembly.
 - Defective directional valve.
 - Pump to motor coupling damaged.
- Pintail of fastener fails to break off:
 - PULL pressure set too low.
 - Worn or defective hose couplers.
 - Hydraulic fluid viscosity not proper or level is low.
 - Hydraulic fluid overheated.
 - Worn or defective directional valve.
 - Internal relief valve set too low or defective.
 - Worn or defective pump.
- Tool will not return when switch is released. (Tool will not push nose assembly off swaged fastener.):
 - RETURN pressure set too low.
 - Hoses not coupled properly.
 - Worn or defective solenoid.
 - Worn or defective pilot valve.
- Motor fails to shut-off when installation cycle is completed:
 - RETURN pressure switch set too high.
 - Hydraulic fluid viscosity not proper or level is low.
 - Hydraulic fluid overheated.
 - Defective limit switch in pressure switch assembly.
- Pump making noise throughout entire cycle:
 - Pump is cavitating-fluid level may be low or fluid viscosity too heavy.
 - Strainer is dirty and clogged.
- Tool operation slow; Entire cycle does occur:
 - Pump is cavitating-fluid level may be low or fluid viscosity is too heavy.
 - Strainer is dirty and clogged.
 - Worn or defective directional valve.
 - Worn or damaged pump.
 - Worn or defective hydraulic couplers.



Limited Warranties

Limited Lifetime Warranty on BobTail® Tools:

Huck International, Inc. warrants to the original purchaser that its BobTail® installation tools manufactured after 12/1/2016 shall be free from defects in materials and workmanship for its **useful lifetime**. This warranty does not cover special order / non-standard products, or part failure due to normal wear, tool abuse or misapplication, or user non-compliance with the service requirements and conditions detailed in the product literature.

Two Year Limited Warranty on Installation Tools:

Huck International, Inc. warrants that its installation tools and Powerigs® manufactured after 12/1/2016 shall be free from defects in materials and workmanship for a period of two years from date of purchase by the end user. This warranty does not cover special order / non-standard products, or part failure due to normal wear, tool abuse or misapplication, or user non-compliance with the service requirements and conditions detailed in the product literature.

90 Day Limited Warranty on Nose Assemblies and Accessories:

Huck International, Inc. warrants that its nose assemblies and accessories shall be free from defects in materials and workmanship for a period of 90 days from date of purchase by the end user. This warranty does not cover special clearance noses, or special order / non-standard product, or part failure due to normal wear, abuse or misapplication, or user non-compliance with the service requirements and conditions detailed in the product literature.

Useful lifetime is defined as the period over which the product is expected to last physically, up to the point when replacement is required due to either normal in-service wear, or as part of a complete overhaul. Determination is made on a case-by case basis upon return of parts to Huck International, Inc. for evaluation.

Tooling, Part(s) and Other Items not manufactured by Huck:

HUCK makes no warranty with respect to the tooling, part(s), or other items manufactured by third parties. HUCK expressly disclaims any warranty expressed or implied, as to the condition, design, operation, merchantability, or fitness for use of any tool, part(s), or other items thereof not manufactured by HUCK. HUCK shall not be liable for any loss or damage, directly or indirectly, arising from the use of such tooling, part(s), or other items or breach of warranty or for any claim for incidental or consequential damages.

Huck shall not be liable for any loss or damage resulting from delays or non-fulfillment of orders owing to strikes, fires, accidents, transportation companies or for any reason or reasons beyond the control of the Huck or its suppliers.

Huck Installation Equipment:

Huck International, Inc. reserves the right to make changes in specifications and design and to discontinue models without notice.

Huck Installation Equipment should be serviced by trained service technicians only.

Always give the serial number of the equipment when corresponding or ordering service parts.

Complete repair facilities are maintained by Huck International, Inc. Please contact one of the offices listed below.

Eastern

One Corporate Drive Kingston, New York 12401-0250
Telephone (845) 331-7300 FAX (845) 334-7333

Outside USA and Canada

Contact your nearest Huck International location (see reverse).

In addition to the above repair facilities, there are Authorized Tool Service Centers (ATSC's) located throughout the United States. These service centers offer repair services, spare parts, Service Parts Kits, Service Tool Kits and Nose Assemblies. Please contact your Huck Representative or the nearest Huck International location (see reverse) for the ATSC in your area.

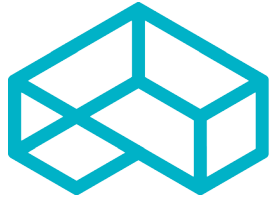

ARCONIC

Innovation, engineered.

Arconic Inc. (NYSE: ARNC) creates breakthrough products that shape industries. Working in close partnership with our customers, we solve complex engineering challenges to transform the way we fly, drive, build and power.

Through the ingenuity of our people and cutting-edge advanced manufacturing, we deliver these products at a quality and efficiency that ensures customer success and shareholder value.

Arconic Fastening Systems world-wide locations:

AMERICAS

Kingston Operations

1 Corporate Drive
Kingston, NY 12401
800-278-4825
845-331-7300
FAX: 845-334-7333

Tucson Operations

3724 East Columbia Street
Tucson, AZ 85714
800-234-4825
520-519-7400

Carson Operations

900 Watsoncenter Road
Carson, CA 90745
800-421-1459
310-830-8200
FAX: 310-830-1436

Acuña Operations

Hidalgo #120
Parque Industrial Amistad
Acuña, Coahuila 26220
Mexico
FAX: 525-515-1776

Waco Operations

PO Box 8117
8001 Imperial Drive
Waco, TX 76714-8117
800-388-4825
254-776-2000
FAX: 254-751-5259

EUROPE

Telford Operations

Unit C, Stafford Park 7
Telford, Shropshire
England TF3 3BQ
+44 1952290011
FAX: 0952-290459

Us Operations

BP4
Clos D'Asseville
95450 Us par Vigny
France
+33 1 30 27 95 00

AUSTRALIA

Melbourne Operations

1508 Centre Road
Clayton, Victoria
Australia 3168
+613 8545 3333
1300 363 049
FAX: +613 8545 3391

Huck is Forever, For the Long Haul, The Future of Fastening Technology, The Future of Assembly Technology, The Future of Tooling Technology, and Tools of Productivity are service marks of Huck International. Huck provides technical assistance regarding the use and application of Huck fasteners and tooling.

NOTICE: The information contained in this publication is only for general guidance with

regard to properties of the products shown and/or the means for selecting such products, and is not intended to create any warranty, express, implied, or statutory; all warranties are contained only in Huck's written quotations, acknowledgments, and/or purchase orders. It is recommended that the user secure specific, up-to-date data and information regarding each application and/or use of such products.

